



United States Steel Corporation

Conservative,
Responsible
Company

Generate a
Competitive
Return on
Capital

Meet Financial
and
Stakeholder
Obligations

A high-resolution image of the Earth from space, showing the Americas. A semi-transparent blue banner with white text is overlaid across the center of the globe.

Making Steel • World Competitive • Building Value



Steelmaking and Power Efficiency

Steel allows **wind power stations** to move offshore.



High-performance steels enable **submerged hydro-power plants**.



For **electrical equipment** steels have been developed to improve efficiencies whilst minimising losses.

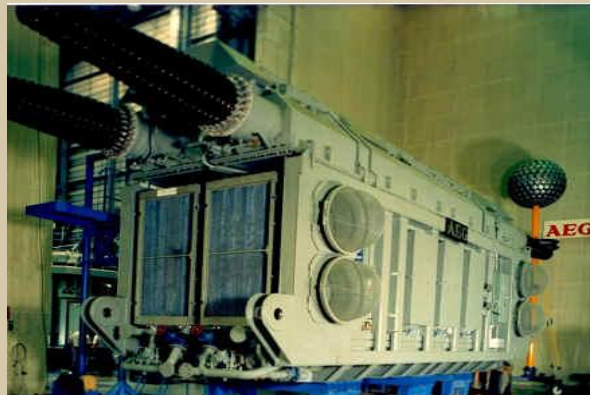

Special high-strength steels allow **improvements on power station efficiency**.

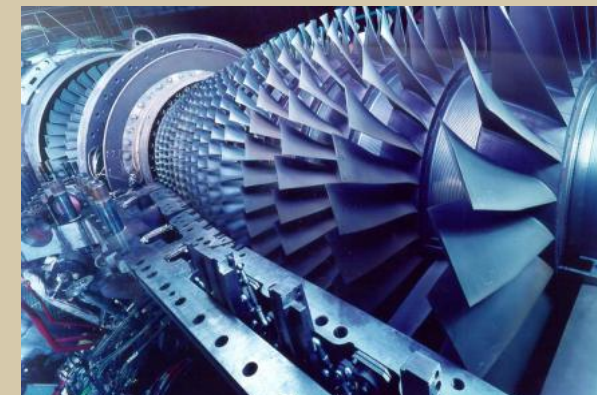



Steelmaking = Energy Intensive Industry

Steelmakers belong to the group of energy intensive industries

In view of :

EU Energy policy, Climate Change Policies, Energy Security of EU and of Slovakia
these share to following characteristics:

- ✓ **Intensive Carbon intensity** and **Energy intensity**
- ✓ Successfull CO₂ and Energy intensity reduction in the past
- ✓ **Intensive R&D** on „breakthrough technologies“
- ✓ Fierce international **competition**
- ✓ High investment and operating costs
(= **need for stable legal and regulatory framework**)





Steelmaking has become more carbon efficient...



CO₂ emission per ton of finished product
Index 100 for 1975

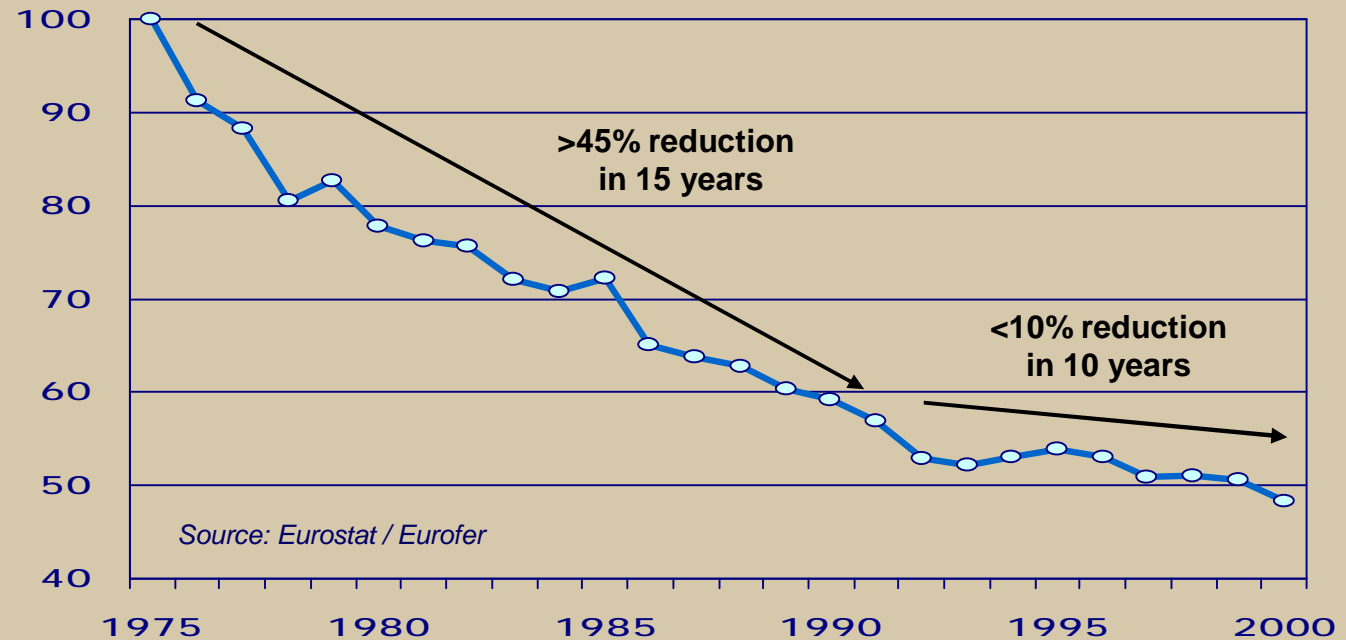

Ø -20% through dramatic improvement of material efficiency

1975: 71.5%

2005: 92%

Ø -14% through increase in scrap availability

1975: 55Mt/y

2005: 80MT/y

Ø -18% through improved BF management and concentration

Ø - 6% through shift away from local C-bearing iron ores

...but further improvement would require technology change



Steelmaking has become more energy efficient and environmentally sufficient...



Total fuel and energy intensity per ton of steel produced (GJ/ton)

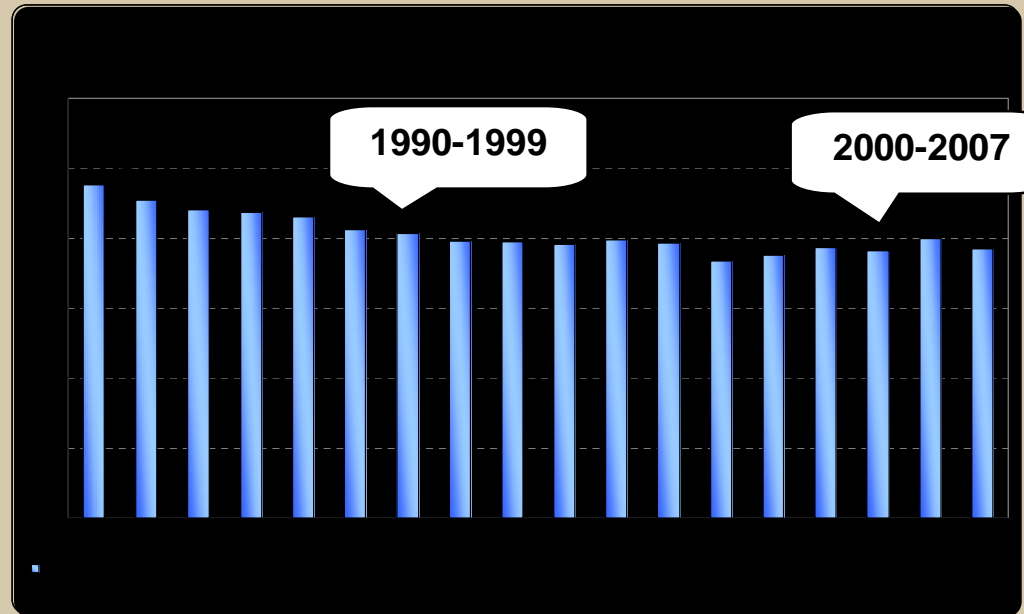

Source: USSK Energy balances

1990-1999:

energy efficiency improvements of the old technology – energy demand decrease

2000-2007:

environmental improvements of the old technology – energy demand balanced

...but further improvement would require:

[encouragement of full utilisation of the secondary energy sources](#)

or

[technology change](#)



Power production as part of integrated steelmaking

Schematic explanation of a secondary energy sources and related Steam and Electricity production

Process related gases (co-generation gases) and their usage

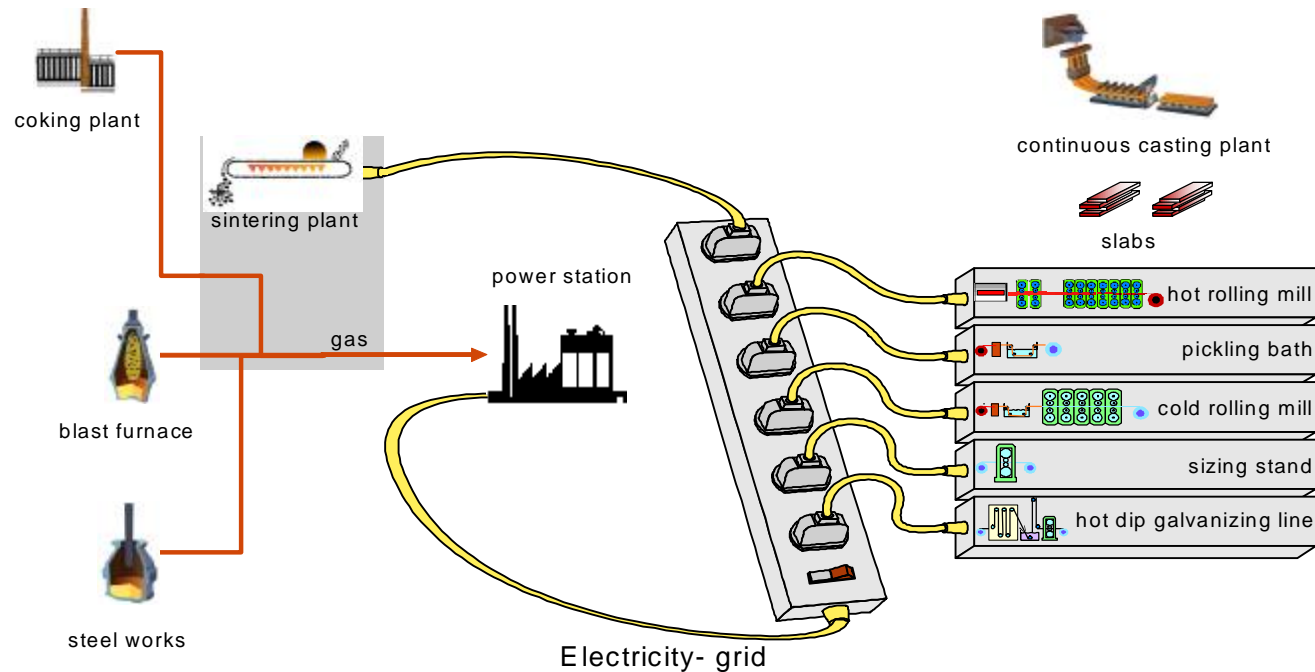



Power production as part of integrated steelmaking

Carbon flow through an integrated site

© Eurofer/Salgzitter AG

Cogeneration gas systems and process-related CO₂-emissions in integrated steel plants - schematic

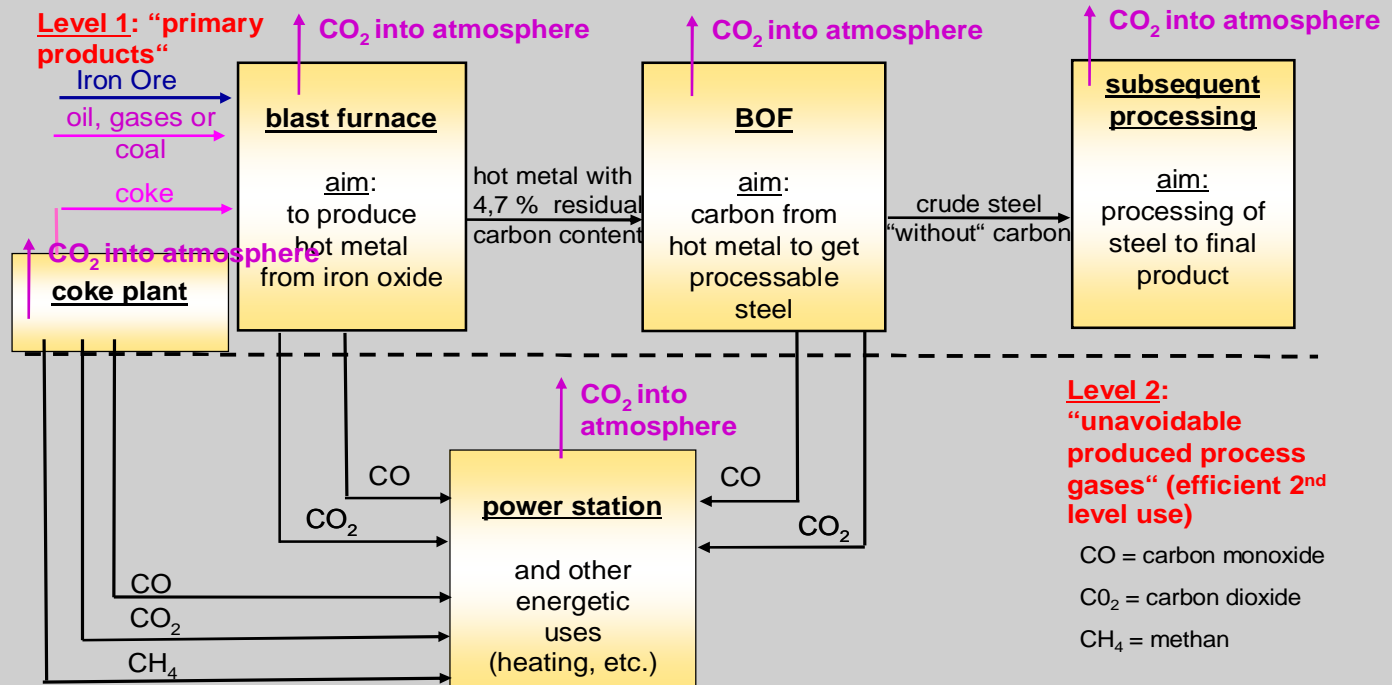



Power production as part of integrated steelmaking

The energy content of “waste gases” currently produced in EU27 metallurgy industry:

- Is equal to the energy content of natural gas of 25 billion cubic meters per annum
- can substitute natural gas equivalent to a CO₂-emission of up to 50 million tons per annum





Steel Industry and EU Energy Policy



Ø Waste gases need to receive support under the same conditions as renewables. Submitting waste gases to CO₂ auctioning would not only discourage the recovery of these unavoidable gases but inevitably lead to carbon leakage and thus to energy losses.

Ø The same accounts for indirect costs through the CO₂ related increase of electricity prices. Electricity-intensive industries cannot compete internationally if they are not compensated for the extra costs until an international agreement is in force that provides for a level playing field.

Ø Secondary energy sources (waste gases, waste heat) from all fields of the industry shall have the same strategy valuation as all other form of energy sources preferred by EU Energy Policy and Energy Security of the member states

Ø High investment and high cost = need for stable legal and regulatory framework